

Air Sniper Inflow 16/36

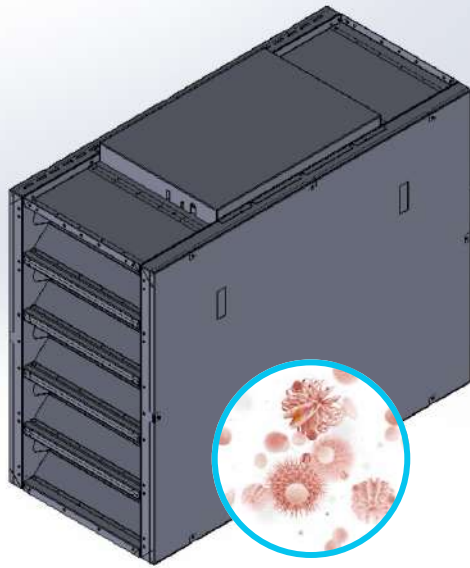

FEATURES

HVAC Easy-Fit Bulkhead

No Ozone

5x UVC Reflective Tunnels

Plug-and-Play

Multi-task colour touchscreen for maintenance and manual monitoring

Wi-Fi enabled for remote monitoring and control

Auto Lamp Detection

99.9% Destruction of Microorganisms

Scientifically proven to destroy 99.9% of airborne viruses, bacteria, and molds.

SPECIFICATIONS

Power Requirements:	220V, 50/60 HZ
Energy Consumption:	8 Amps @ 220V
Weight:	100 lbs (45 kg)
Control Panel:	Colour touch screen Wi-Fi enabled
Housing Material:	Aluminum
Dimensions:	45" (L) x 37" (H) x 21" (D)
Electrical Safety Certification:	ETL Certification
Airflow:	Flow switch detection on/off cycle
Maximum CFM Allowance:	5,000 CFM
Static Pressure:	0.98 wc
Number of Bulbs:	50x 36-Watt bulbs

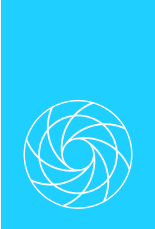

DETAIL DRAWINGS

