

SURNA 250 PPD DEHUMIDIFIER

OPERATING AND MAINTENANCE MANUAL





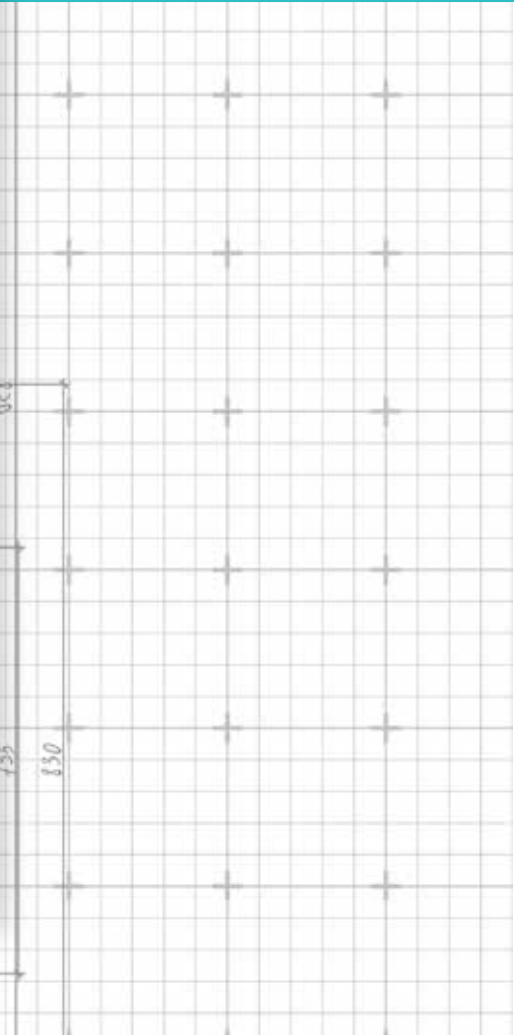
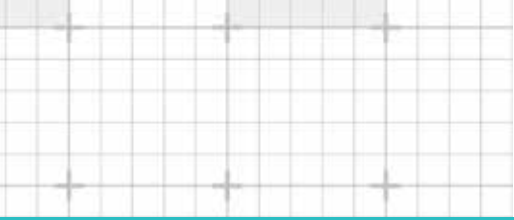
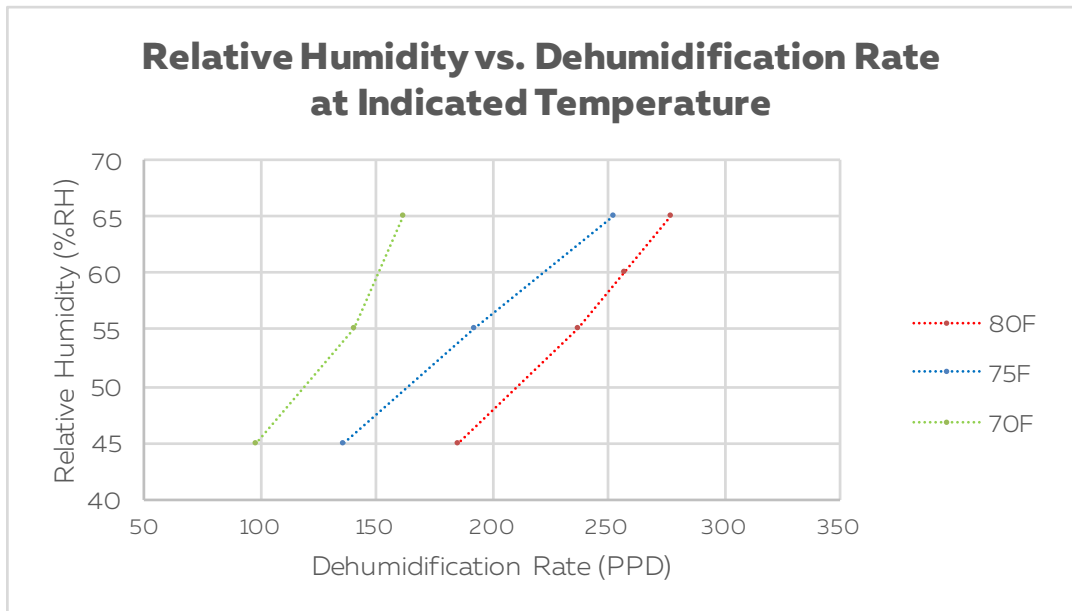

TABLE OF CONTENTS

Specifications	4
Technical Description	5
Warnings	6
Warranty Information	8
Installation Instructions	10
Operation Instructions	18
Routine Maintenance	19
Troubleshooting	21

SPECIFICATIONS

PHYSICAL		250 PPD 3-250
Length		25.4 in
Width		26 in
Height		17.3 in
Weight		132 lbs
Electrostatic Air Filter		11.69" x 22.25" x 1"
Condensate Drain		3/4" NPT
ELECTRICAL		
Volts - Phase		208/230V Single
Nominal Current Draw		12.8A / 12.0A
Maximum Overcurrent Protection		20A
Power Factor		.99
PERFORMANCE		



TECHNICAL DESCRIPTION

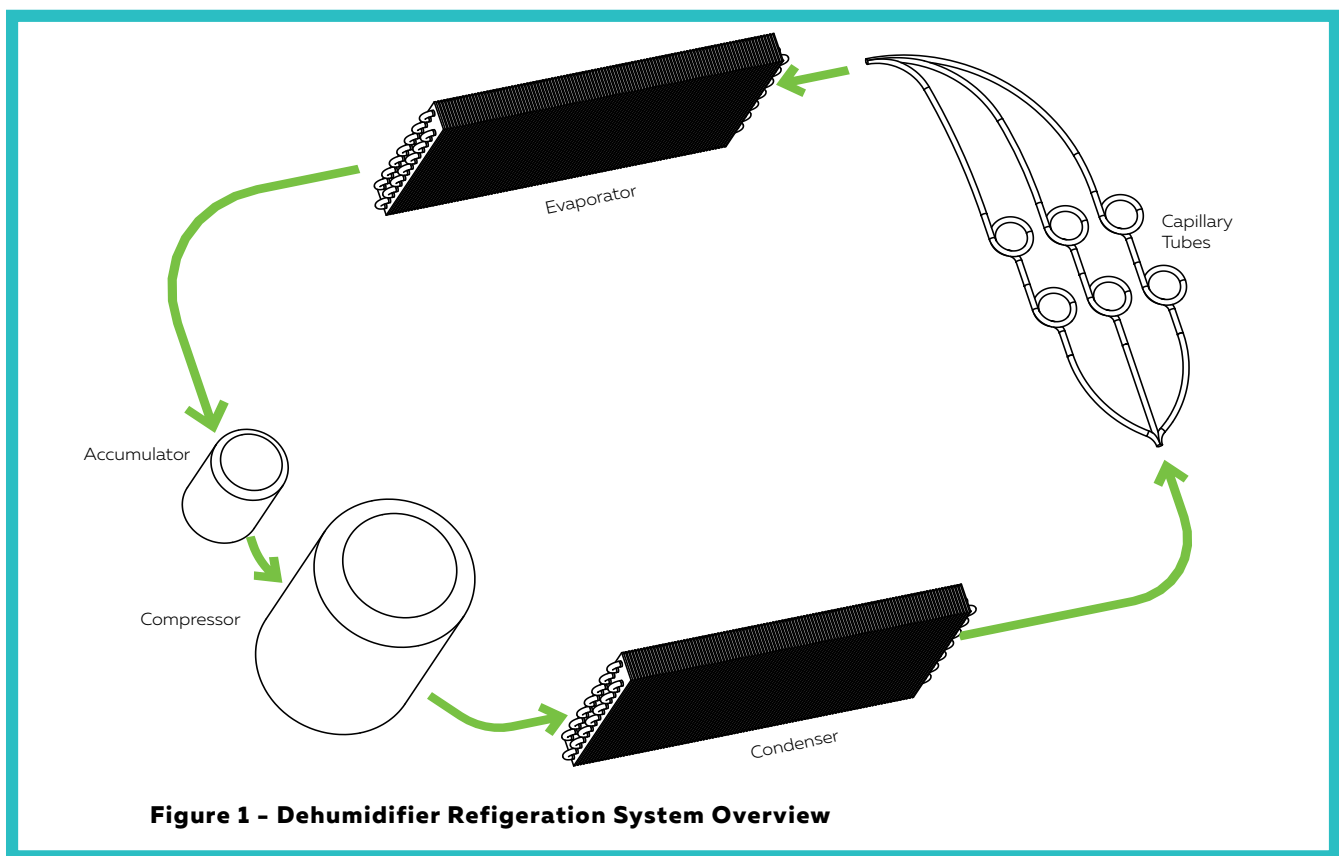

Figure 1 - Dehumidifier Refrigeration System Overview

The Surna dehumidifier uses refrigerant R410a on the vapor compression cycle to remove heat and moisture from the environment. Low-pressure refrigerant gas is compressed in the compressor and flows to the condenser coil. The refrigerant condenses to a liquid and gives off heat to the outside air. The refrigerant pressure and temperature are reduced by passing through a series of capillary tubes which act like an expansion valve. Refrigerant then flows to the evaporator coil. The evaporator coil is where heat

is transferred from the incoming air to the liquid refrigerant causing it to evaporate. This is the point in which moisture condenses out of the humid air through condensation. Next, refrigerant flows from the evaporator to the accumulator, entering the accumulator as a mixture of liquid and gas. The accumulator prevents liquid refrigerant from entering the compressor, boiling off liquid so that only hot, low pressure gas enters the compressor and the cycle begins again.

WARNINGS

DEFINITIONS

CAUTION: Risk of minor/moderate injury if precaution not taken.

WARNING: Risk of death/serious injury if warning isn't heeded.

DANGER: Risk of death/serious injury if danger isn't avoided.

SAFETY SYMBOLS USED



CAUTION: Important information, read the provided instructions carefully



WARNING: Potential electric shock hazard



WARNING: High voltage



Protective earth connection



Action prohibited

DEHUMIDIFIER SAFETY GUIDE



Please read the information in this document carefully prior to attempting the installation, operation and/or servicing of the dehumidifier unit. This document contains all information required to install and operate the Surna dehumidifier device. Failure to follow the directions provided could cause damage to the dehumidifier equipment and/or accessory equipment, damage to building facilities, and/or serious injury or death to the operator. Please adhere to all applicable safety guideline requirements in this document and all applicable electrical and mechanical jurisdictional codes. Using Surna dehumidifying equipment in a manner not described in this manual may void unit warranty.



Prior to providing power to the equipment, be sure to inspect the area for water spills, which may present a shock hazard to the user. Take extra care to mount accessory electrical equipment away from areas regularly exposed to water. Be sure to provide secure wire and cable routing to protect personnel from shock hazards.



Consult with a licensed electrician before attempting electrical installation. DO NOT operate the unit outside specified operating parameters as given in the **intended application** section. Only operate the equipment with an appropriately sized switch or circuit breaker in place. Only operate equipment with adequate wire sizes and current carrying capacity. The switch or circuit breaker shall be accessible without the use of a tool, shall be easily accessible to users, shall be clearly marked with "ON" and "OFF" positions, and shall disconnect all

current carrying conductors simultaneously.



Prior to installing the dehumidifier, apply power to the unit and verify the fan and compressor are operating normally.



The power supply cord contains a ground fault circuit interrupter (GFCI) that senses damage to the power cord. To test your power supply cord, do the following:

1. Plug in the Surna Dehumidifier.
2. The plug head has two buttons TEST/RESET. Press the TEST button and the RESET button will pop out.
3. Press the RESET button and the TEST button disengages.
4. The power supply cord is now supplying electricity to the unit. Power is indicated by a green light on the plug head.

DO NOT operate this unit with a damaged power cord. If the power cord is damaged it must be replaced by the manufacturer or a qualified/licensed service technician.



DO NOT use extension cords or plug adapters. These actions may result in a fire hazard or electric shock.



This unit must be connected to a protective earthing system prior to operation. DO NOT remove the grounded connection while power is being supplied to the Surna dehumidifier. Doing so presents an electric shock hazard to users and service personnel.



This device is intended for indoor use only and should be protected from rain and flooding.



This equipment is not meant for connection to a ducting system.



Only use Surna supplied or recommended equipment with the Surna dehumidifier.



Care must be taken when handling sheet metal. Sheet metal parts have sharp edges and could cause serious bodily injury.



The components of this unit have been inspected at the factory and readied for shipment. Upon receiving the shipment a visual inspection of the packaging must be performed. Any shipping damage must be noted at time of delivery.



DO NOT use this unit as a bench or table.

WARRANTY INFORMATION

Equipment manufactured by Surna ("Company"), the warranty shall exist for a period of twelve (12) months from initial start-up or eighteen (18) months from date of shipment, whichever period is shorter, against failure due to defects in material and/or manufacturing and warranted to the capacities and ratings set forth in Company's catalogs and bulletins ("Warranty").

Equipment, material, and/or parts that are not manufactured by Company are not warranted by Company and carry such warranties as may be extended by the respective manufacturer.

Exclusions from this Warranty include damage or failure arising from: wear and tear; corrosion, erosion, deterioration; modifications made by others to the Equipment; repairs or alterations by a party other than Company that adversely affect the stability or reliability of the Equipment; vandalism; neglect; accident; adverse weather or environmental conditions; abuse or improper use; improper installation; commissioning by a party other than Company; unusual physical, electrical or mechanical stress; lack of proper startup or maintenance as recommended by Company; operation with any accessory, equipment or part not specifically approved by Company; and/or refrigerant not recommended or supplied by Company.

Company shall not be obligated to pay for the cost of lost refrigerant or lost product or any other direct, indirect, or consequential damages. Company's obligations and liabilities under this Warranty are limited to furnishing replacement equipment or parts, at its option, FCA (Incoterms 2000) factory or warehouse (f.o.b. factory or warehouse for US domestic purposes) at Company-designated shipping point, freight allowed to

Company's warranty agent's stock location, for all non-conforming Company manufactured Equipment which have been returned by Customer to Company.

Returns must have prior written approval by Company and are subject to restocking and replacement charges where applicable.

No warranty liability whatsoever shall attach to Company until Customer's complete order has been paid for in full and Company's liability under this Warranty shall be limited to the purchase price of the Equipment shown to be defective.

Additional warranty and service protection is available on an extra-cost basis and must be in writing and agreed to by an authorized signatory of the Company.

The warranty excludes: (a) labor, transportation and related costs incurred by the Dealer or Customer; (b) re-installation costs of repaired equipment; (c) re-installation costs of replacement equipment; (d) removal costs of equipment; (e) consequential damages of any kind; and, (f) reimbursement for loss caused by interruption of service.

EQUIPMENT MANUFACTURED BY COMPANY THAT INCLUDES A REQUIRED START-UP AND SOLD IN NORTH AMERICA WILL NOT BE WARRANTED BY COMPANY UNLESS COMPANY OR ITS AUTHORIZED AGENT PERFORMS THE EQUIPMENT STARTUP.

COMPANY MAKES NO REPRESENTATION OR WARRANTY, EXPRESS OR IMPLIED, REGARDING PREVENTION OF MOLD/MOULD, FUNGUS, BACTERIA, MICROBIAL GROWTH, OR ANY OTHER

CONTAMINATES.

EXCEPT FOR COMPANY'S WARRANTY EXPRESSLY SET FORTH HEREIN, COMPANY DOES NOT MAKE, AND HEREBY EXPRESSLY DISCLAIMS, ANY WARRANTIES, EXPRESS OR IMPLIED CONCERNING ITS PRODUCTS, EQUIPMENT OR SERVICES, INCLUDING, WITHOUT LIMITATION, ANY WARRANTY OF DESIGN, MERCHANTABILITY OR OF FITNESS FOR A PARTICULAR PURPOSE, OR OTHERS THAT ARE ALLEGED TO ARISE FROM COURSE OF DEALING OR TRADE.

DEHUMIDIFIER ORDER

Below is a list of all parts provided with each Surna dehumidifier. The following are included with the order (quantities are dependent on individual order).

1. Surna 250 PPD dehumidifier
2. Surna 250 PPD dehumidifier product manual
3. Humidistat
4. 15 ft of thermostat wire
5. PVC condensate trap

INTENDED APPLICATION

The Surna dehumidifier is intended to operate in temperatures above 70°F (21°C) and a relative humidity of 45% or higher.

NOTE: Depending on room height, temperatures and relative humidity levels at canopy level may differ from the dehumidifier mounting position. In this case, it is recommended to implement a form of air mixing or air destratification fans.

CAUTION: Surna dehumidifiers are not designed to operate in temperatures below 70°F (21°C). If the unit is operated below 65°F (18°C), the evaporator may frost up. Damage due to improper operation is not covered by warranty.

INSTALLATION INSTRUCTIONS

MECHANICAL



Mounting details and information are summarized in **figures 2-6 on subsequent pages.**

The Surna dehumidifier is designed for overhead mounting within the space that requires conditioning. Prior to mounting, confirm that the supporting surface and mounting means are suitably rated for the dehumidifier weight load (see **specifications** section of this document). When mounting, verify the tops of the mounting brackets are leveled with respect to one another to ensure proper drainage. When the brackets are level, the unit will be sloped towards the condensate drain.

The Surna dehumidifier requires a minimum of 12 inches (30.5 cm) vertical clearance above the unit, and a minimum of 24 inches (61 cm) (recommended 72 inches (182.8 cm)) of clearance on the air intake and exhaust sides when placed next to walls or structures. When placed next to fan coils or other mechanical equipment, the Surna dehumidifier requires 36 inches (91.5 cm) of clearance on the air intake and exhaust sides.

DO NOT position the Surna dehumidifier air intake/exhaust in-line with cold air exhaust from other air handling or cooling units/circulatory fans. Improper positioning will decrease unit efficiency and could cause damage to the unit.

ELECTRICAL

This unit includes a plug and power cord with GFCI built in, and should be plugged into a dedicated outlet. DO NOT use an extension cord. Read the **specifications** section of this document for more information on the power and circuit breaker requirements.

An On/Off switch located on the front face of the unit is used to provide power to the equipment. The fan in the unit will run with the switch in the "OFF" position, but the compressor will not run while the switch is in the "OFF" position. The On/Off switch should be switched to "ON" to begin normal operation. An external switch or circuit breaker shall be used as the primary disconnect device. The disconnect device shall be accessible to users, have a clearly marked On/Off position and must disconnect all current carrying conductors simultaneously.

A humidity controller (humidistat) is supplied with the Surna dehumidifier. To use the humidistat as a controller, install the switch wire in the provided connector block and make the connection to the mating end attached to the exterior of the unit.

PLUMBING

Condensate drains should be connected to a waste or reclamation system in order to direct the condensate out of the space. Ensure condensate lines remain unobstructed to avoid unattended spillage or drain pan overflow. Use of a p-trap (reference **figure 2**) is required to avoid pressure and vacuum related issues, which can negatively affect condensate drainage. Following plumbing installation, the system should be checked for leaks prior to attempting unattended operation. Insulate the condensate drain a minimum of 72 inches (182.8 cm) from the unit to avoid condensate pooling on the bottom of the drain pipes and dripping.

MOUNTING DIAGRAM

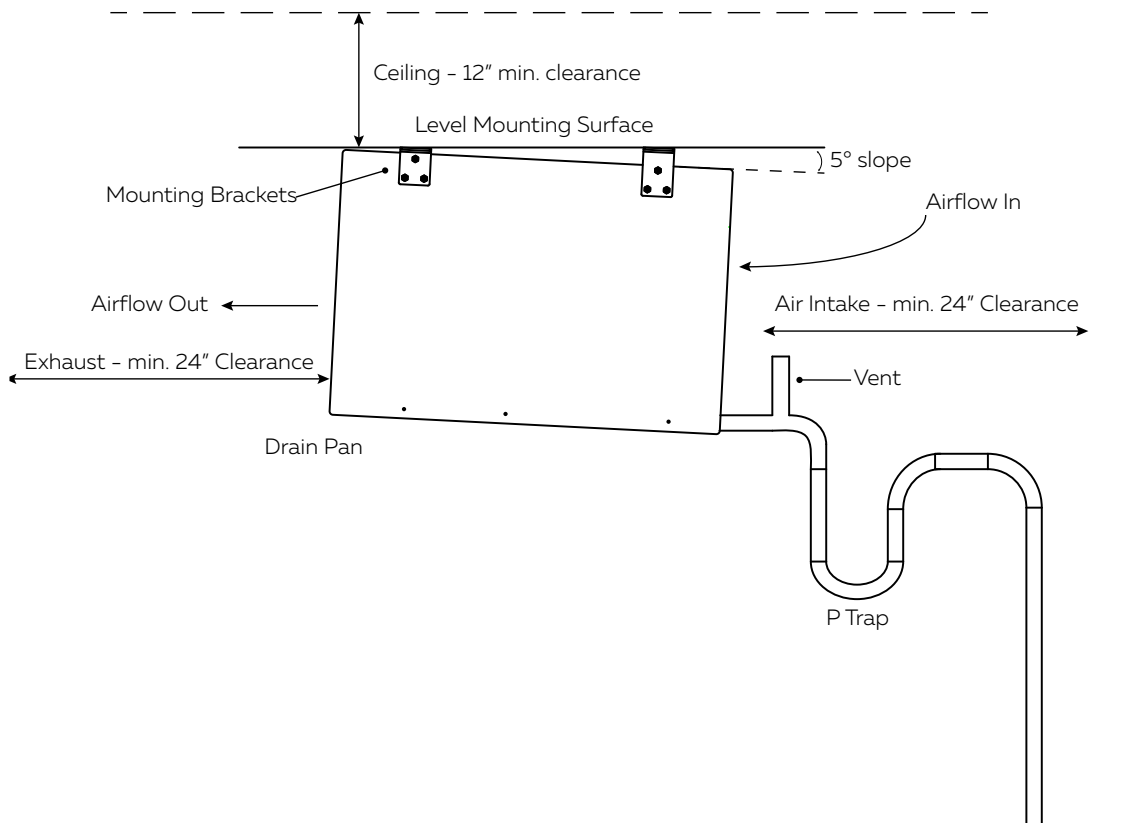
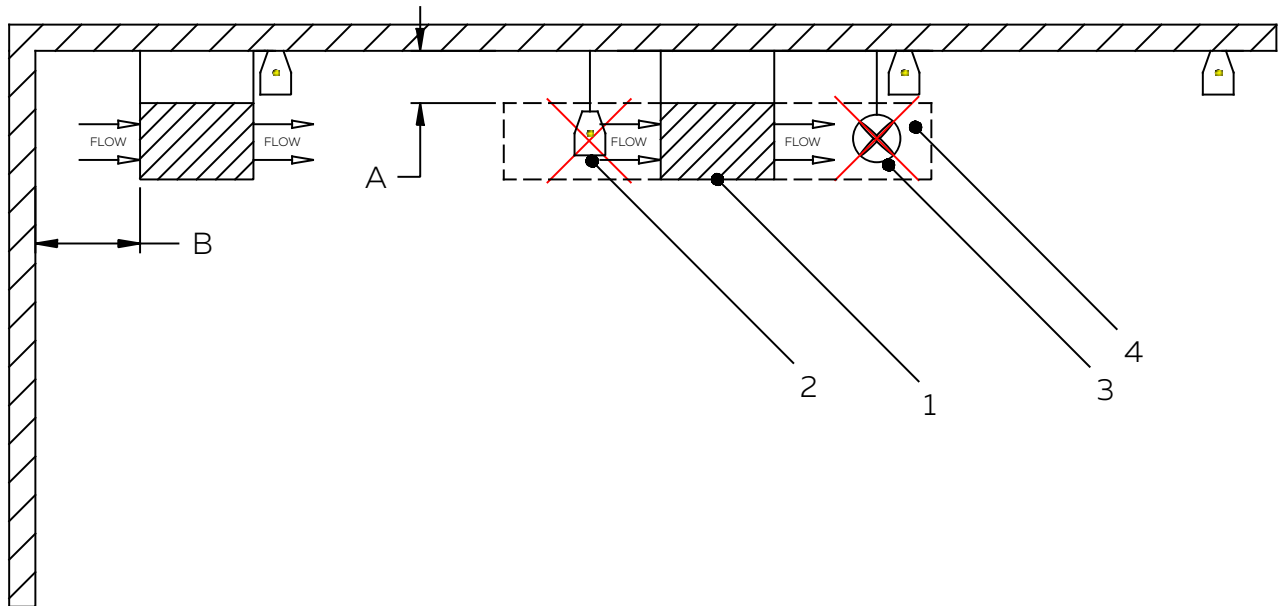

Figure 2- Installation diagram shows proper mounting of Surna dehumidifier

REQUIRED UNIT CLEARANCES



A	Minimum 12 inches (30.5 cm) of clearance above and below
B	Minimum clearance of 24 inches (61 cm) (recommended 72 inches (182.8 cm)) from any wall or structure in front of intake or discharge
1	Surna dehumidifier
2	Do not block intake or discharge
3	Do not direct any air into intake or discharge via fans or vents
4	No conditioned air discharge or circulating fans within minimum 36 (91.5 cm) inches (recommended 72 inches (182.8 cm)) from intake or discharge of unit

Figure 3- Required minimum clearances for Surna dehumidifier

PROPER UNIT AIRFLOW

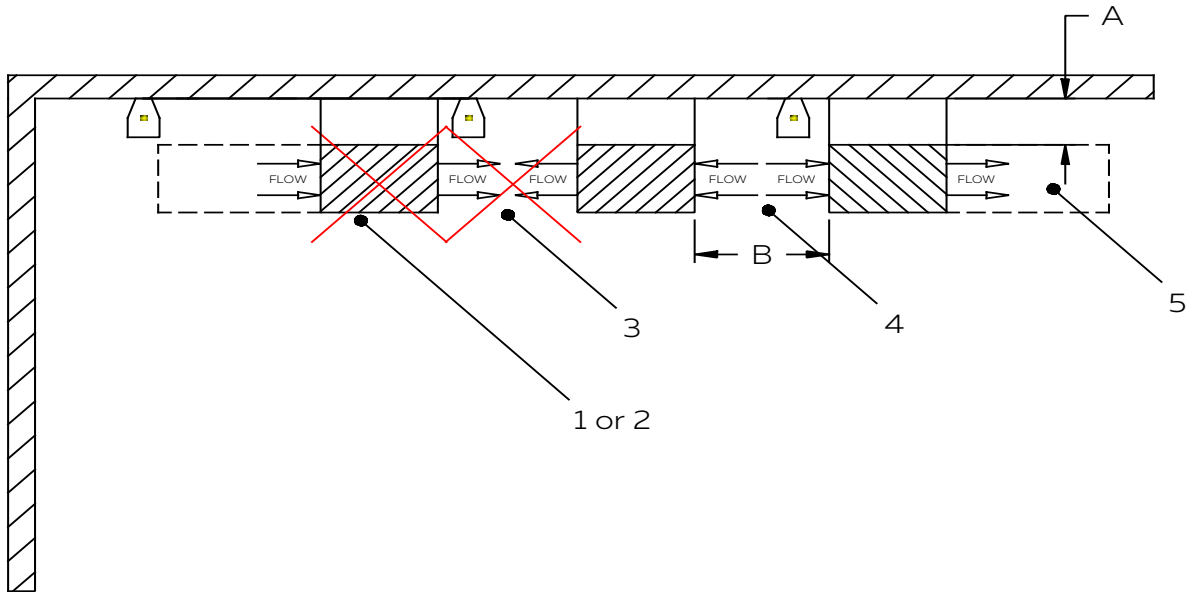

A	Minimum 12 inches (30.5 cm) of clearance above and below
B	Minimum clearance of 24 inches (61 cm) (recommended 72 inches (182.8 cm)) between 2 units with adjacent intakes

1	Surna dehumidifier
2	Surna fan coil
3	DO NOT exhaust into units intake or exhaust
4	Units may disregard "3" if intakes are opposing and a minimum of 24 inches (61 cm) (recommended 72 inches (182.8 cm)).
5	No conditioned air discharge or circulating fans within minimum 36 inches (91.5 cm) from intake or discharge of unit

Figure 4 - Proper unit positioning with regard to airflow for Surna dehumidifier

PROPER VERTICAL OFFSET

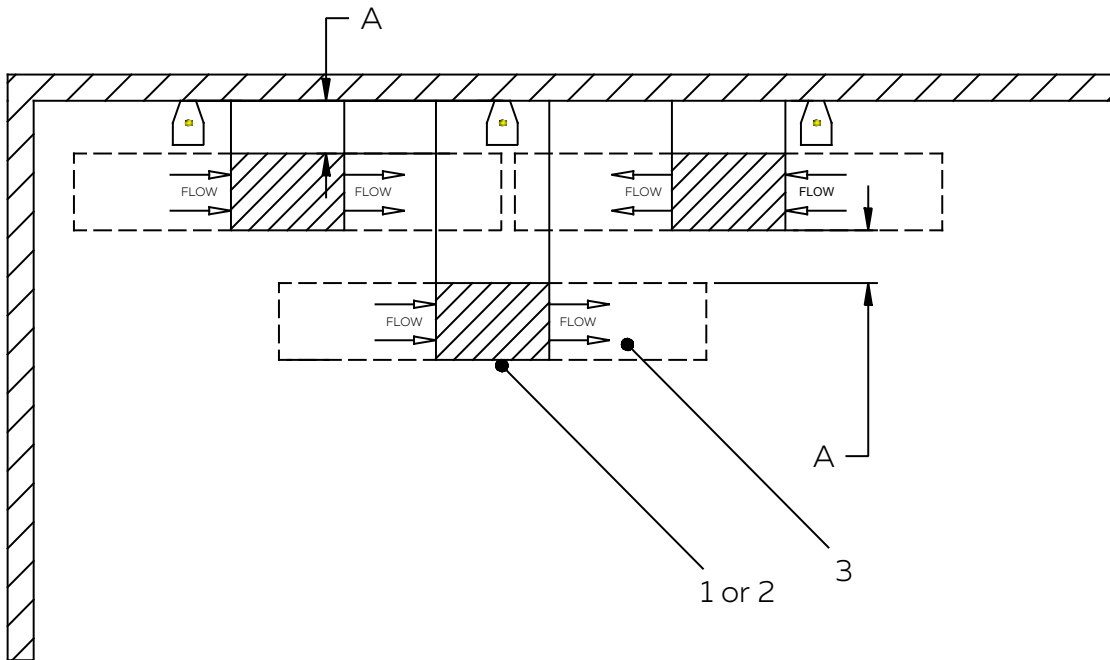

A	Minimum 12 inches of clearance above and below
---	--

1	Surna dehumidifier
2	Surna fan coil
3	No conditioned air discharge or circulating fans within minimum 36 inches (91.5 cm) (recommended 72 inches (182.8 cm)) from intake or discharge of unit

Figure 5 - Limited clearance offsets for Surna dehumidifier

BIRD'S EYE UNIT CLEARANCES

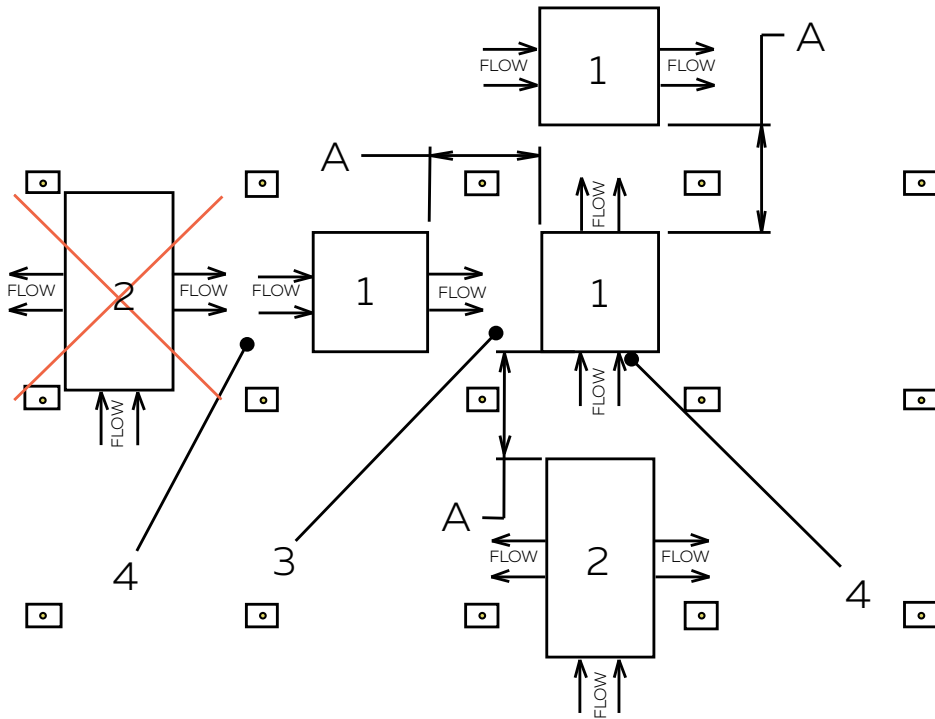

1	Surna dehumidifier
2	Surna fan coil
3	Oppose flow by 90 degrees for neighboring units
4	No conditioned air discharge or circulating fans within minimum 36 inches (91.5 cm) (recommended 72 inches (182.8 cm)) from intake or discharge of unit.

A	Minimum 24 inches (61 cm) (recommended 72 inches (91.5 cm))
---	---

Figure 6 - Bird's eye view of proper installation of Surna dehumidifier with recommended clearances

WIRING DIAGRAM

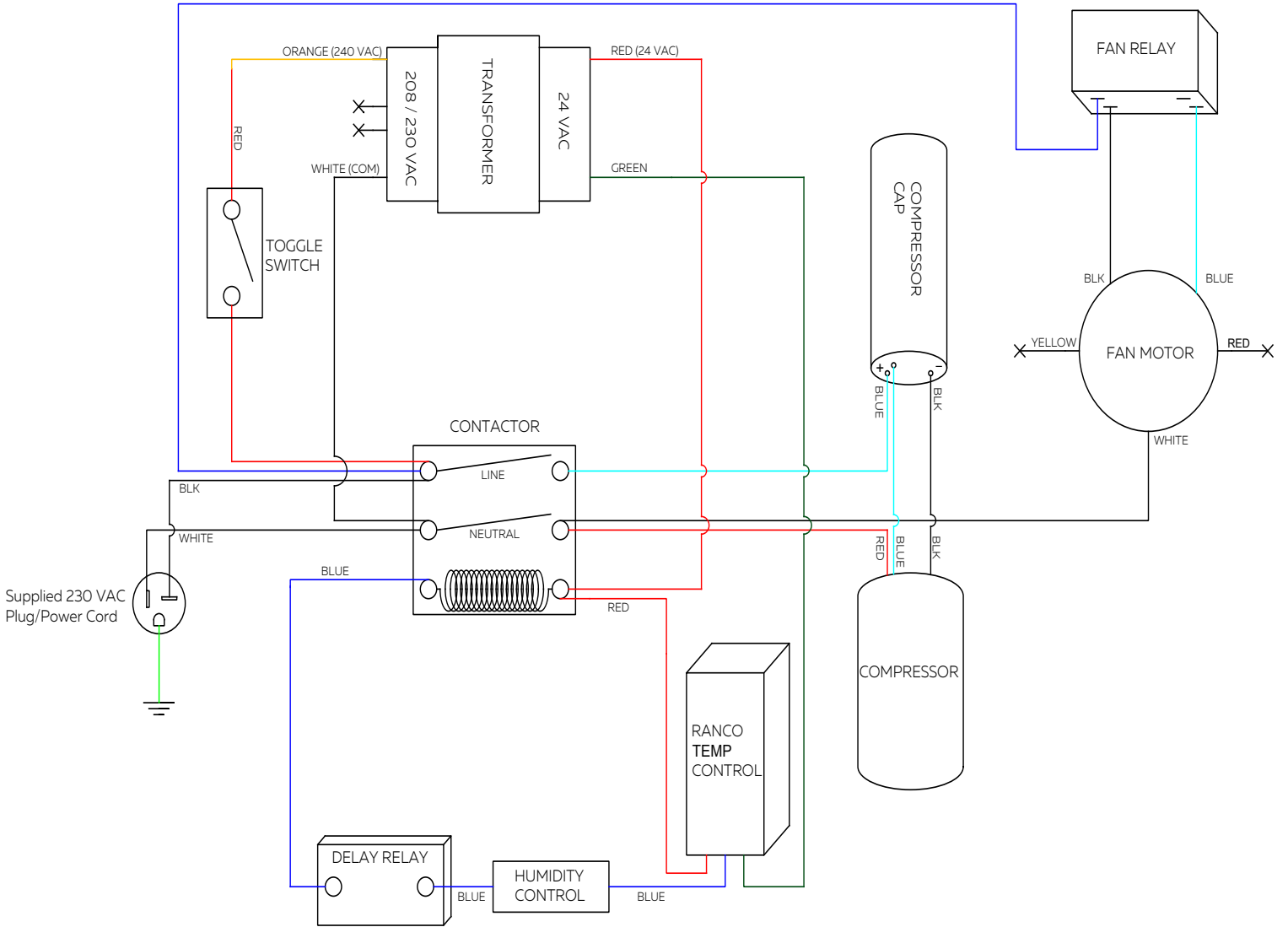

Figure 7 - Surna dehumidifier wiring diagram

OPERATION INSTRUCTIONS

To start normal operation, flip the switch on the front of the unit to the "ON" position and set the provided humidity controller to the desired setting for the space.

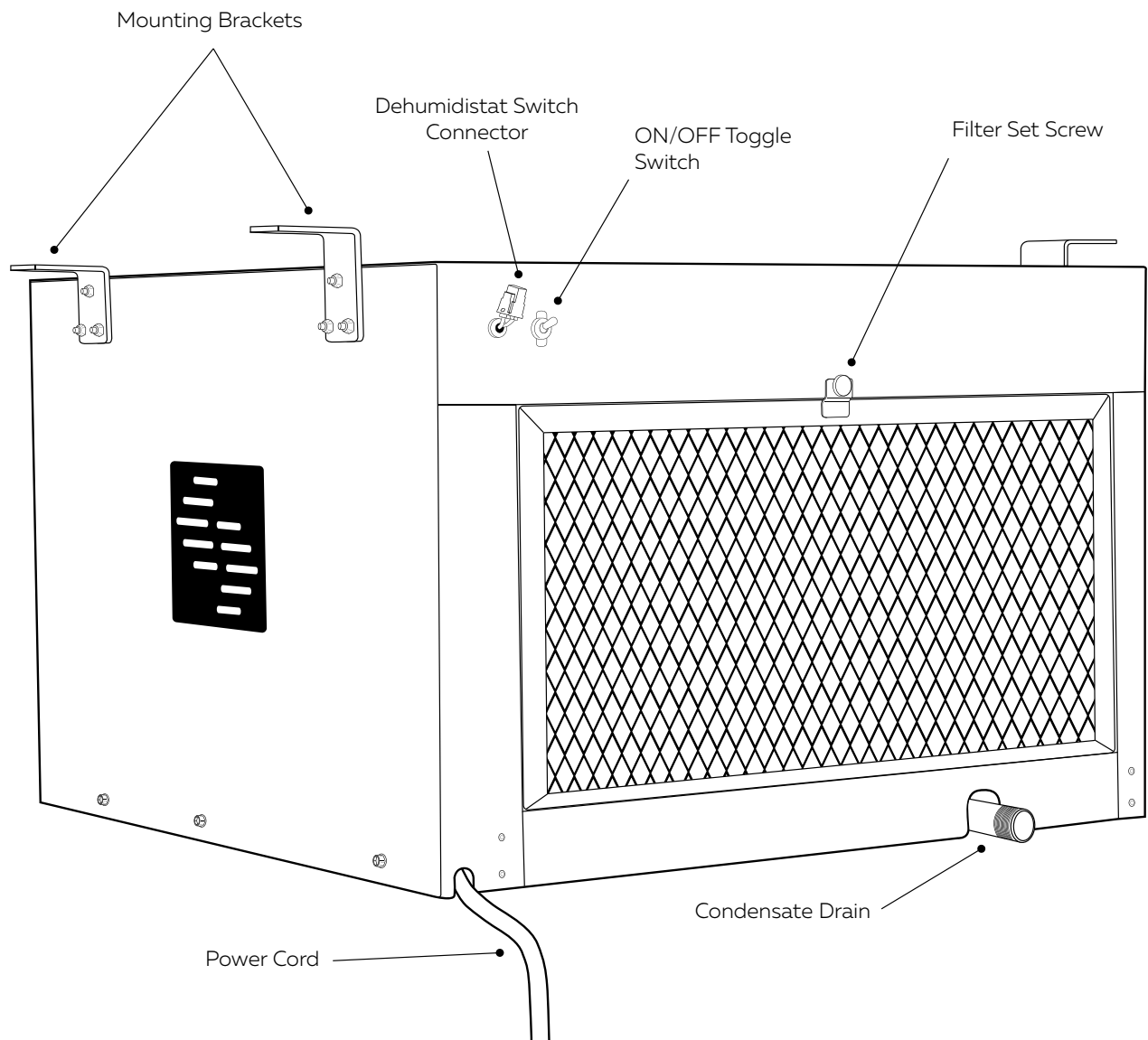

Figure 7 - Installation connection

ROUTINE MAINTENANCE

This product is designed to provide many years of dependable, trouble free operation when properly maintained. Failure to provide periodic check-ups and cleaning can result in excessive operation cost and/or equipment failure. Required routine maintenance consists of coil cleaning, filter cleaning/changing, and condensate drain inspection/cleaning.



WARNING: Before performing any maintenance or service, verify unit is disconnected from power source. Servicing the Surna dehumidifier, with its high pressure refrigerant system, high voltage circuitry, and internal fan, presents a health hazard which could result in death, serious bodily injury, and/or property damage. DO NOT attempt maintenance or repairs unless you are properly trained to do so.

Evaporator and condenser coils can be vacuumed out. To access the evaporator coil, remove set screw and remove filter. Use caution when cleaning the coils. The coil fins are sharp and may cause injury if improperly handled. The coil fins are extremely delicate and can be damaged easily. Damaged coil fins can reduce air flow and negatively affect the performance of the unit. DO NOT use coil cleaner that is designed for outdoor coils, as it may be corrosive. The Surna Dehumidifier comes equipped with an electrostatic filter. If properly maintained, electrostatic filters will provide long lasting filtration. It is recommended to clean the filter every 30 days, at a minimum. Operating the unit with a dirty filter

will reduce dehumidifier capacity and efficiency and may cause the compressor to unnecessarily cycle on and off. DO NOT operate the unit without the filter.

CLEANING THE FILTER

1. Remove filter set screw.
2. Remove filter.
 - a. If the filter is ripped or physically damaged, it should be replaced.
3. Check filter for cleanliness.
 - a. Hold filter up to light source, and check for transparency.
 - i. The more light showing through, the cleaner the filter.
 - ii. If light cannot be seen, the filter needs to be cleaned.
4. The filter can be vacuumed out or washed with water.
 - a. When washing the filter with water, spray water through the filter in the opposite direction of the air flow indicator.
 - b. When vacuuming the filter, ensure that the vacuum is pulling dirt and debris from the filter in the opposite direction of the air flow indicator. This will push dust and debris out of the filter instead of into the filter.
 - c. Airflow is indicated by a directional arrow on the side of the filter.

CLEANING THE FILTER (CONTINUED)

5. Spray the filter with mild detergent (only if washing with water) (optional)
 - a. When done cleaning, it should be possible to see light showing through the filter.
 - b. If it is not possible to clean the filter to the point where light is able to shine through, the filter should be replaced.
6. Let filter air dry for at least 10 minutes. The filter can be used damp, but not dripping wet.
 - a. Ensure drain holes on the filter are facing down for proper drainage and drying.
7. Reinstall the filter with the air flow indicator pointing in, toward the evaporator coil.



TROUBLESHOOTING

Prior to calling Surna technical support, follow these troubleshooting steps. Steps 1-6 may be handled by anyone with basic knowledge of the dehumidifier set up; steps 7-12 should be handled by a licensed HVAC technician. To avoid voiding the warranty, please call Surna at 303.993.5271 before having a technician perform work.



WARNING: Before performing routine maintenance or service, verify unit is disconnected from power source. The Surna dehumidifier contains high pressure refrigerant, high voltage circuitry, and an internal fan. Improper operation could result in serious bodily injury, death and/or property damage.

CUSTOMER

1. Verify that unit is plugged in and GFCI is not tripped.
2. Verify power to outlet is on.
3. Ensure circuit breaker has not tripped.
4. Verify toggle switch located on the dehumidifier is in the "on" position. (Fan will constantly run even if the toggle switch is in the "off" position.)
5. Verify that filter and evaporator coil are clean. (The filter should be cleaned every 30 days.)
6. Verify the Humidistat is set to "on."

NOTE: The Surna dehumidifier is intended to operate in temperatures above 70°F (21°C) and relative humidity of 45% or higher. Temperature

and relative humidity affect performance. Contact Surna with questions. If steps 1-6 are unsuccessful, contact Surna Technical Support at 303.993.5271 before calling a technician.

TECHNICIAN

7. Check airflow conditions of unit. Air should be felt being pulled through the evaporator coil and pushed out of the condenser coil.
8. Check that filter and evaporator coil on the unit are clean. If not, clean these items with water and an approved coil cleaner.
9. Check condensate plumbing. P-traps are required.

If steps 7-9 are unsuccessful, remove dehumidifier from ceiling and remove top cover.

10. Check internal temperature controller (Ranco) within the unit; contact Surna for detailed Ranco troubleshooting instructions. Verify the Ranco set point is 32°F (0°C).
11. Check temperature probe. Verify the probe is fully inserted into the evaporator coil for accurate temperature readings. If installed correctly, the temperature probe should not be visible.

If steps 10-11 are unsuccessful, contact Surna for further instructions on testing environmental conditions and/or unit refrigerant charge.



A 1780 55th Street, Suite A
Boulder, CO 80301

P 303.993.5271

E info@surna.com

SURNA.COM